

## Rectangular Manways

Rectangular manways are used in a variety of different applications including dairies, breweries and hygienic industrial washing machines and autoclaves. Manways are also used by the paint and chemical industry for solvent and product storage vessels.

Available with both inward and outward opening covers, their shape compliments perfectly with flat surface mounting applications.

Consequently these manways are often the preferred choice for cubic vessels and flat sided tanks and cabinets.

Here these manways are usually installed either on the top of the vessels for easy access or are side mounted for easy inspection and cleaning.

There is now a comprehensive range of sizes offered from small inspection hatches at 130mm x 310mm through to 750mm x 750mm doors that facilitate entry to vessels with breathing apparatus.

### Features and Options:

- Sizes from 130mm x 310mm through to the 750mm x 750mm
- Special neck rings available for glass fibre and concrete tanks
- FDA approved seals in EPDM, Silicone, Viton®/FKM or Nitrile
- Working pressures of up to 2.2 Bar
- Alternative hinge mechanisms allow vertical and horizontal installation
- Sight Glass and Pressure / Vacuum Relief Valves and Mushroom Inlets



Dimensions are provided in good faith but may be subject to change, if dimensions are critical, please call the office to confirm all sizes before placing an order.

[DS Rectangular Manways v1.4.doc](#)

Page No: 1

## M12A-A01 – Rectangular Manway – Outward Opening

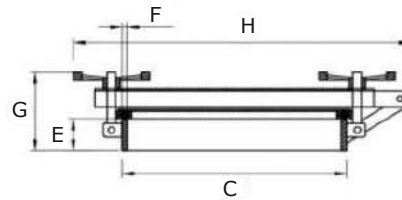

Section Detail

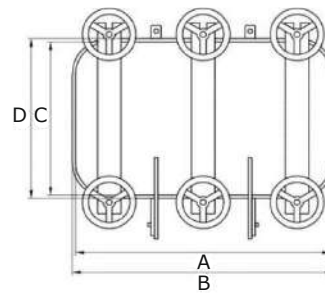

Plan Detail

A (mm)	B (mm)	C (mm)	D (mm)	E (mm)	F (mm)	G (mm)	H (mm)	Working Pressure Range (bar)	Weight (kg)	Part No
734	750	454	470	70	8	190	717	-1.0 / +1.0	36.0	<a href="#">M12A-A01-7541</a>
730	750	450	470	70	10	190	717	-1.0 / +1.0	43.0	<a href="#">M12A-A01-7542</a>
600	616	600	616	70	8	196	~	-1.0 / +1.0	~	<a href="#">M12A-A01-6001</a>
600	620	600	620	70	10	196	~	-1.0 / +1.0	~	<a href="#">M12A-A01-6002</a>
732	752	732	752	70	10	190	~	-1.0 / +1.0	~	<a href="#">M12A-A01-7502</a>

**Materials:**

1. M12A-A: 316L Stainless Steel
2. M12A-C: 304L Stainless Steel

**Other materials also available:**

1. L – Natural Rubber
2. E – EPDM
3. N – Nitrile
4. V – FKM

Lid thickness: 4 mm

Dimensions are provided in good faith but may be subject to change, if dimensions are critical, please call the office to confirm all sizes before placing an order.

[DS Rectangular Manways v1.4.doc](#)

Page No: 2

## M12A-A02/03 – Rectangular Manway – Outward Opening

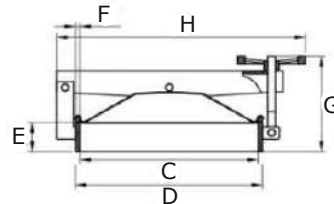

Section Detail

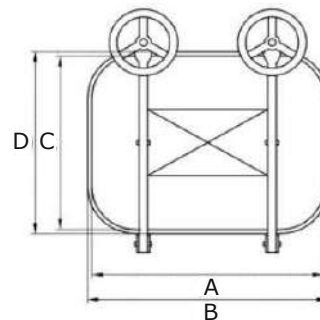

Plan Detail

A (mm)	B (mm)	C (mm)	D (mm)	E (mm)	F (mm)	G (mm)	H (mm)	Working Pressure Range (bar)	Weight (kg)	Part No
531	555	411	435	60	8	228	581	-1.0 / +1.2	19.0	M12A-A02-5311
531	555	411	435	60	10	228	581	-1.0 / +1.2	23.0	M12A-A02-5312
531	555	411	435	60	12	228	581	-1.0 / +1.2	25.0	M12A-A02-5313
531	555	411	435	80	10	238	581	-1.0 / +1.2	~	M12A-A02-5314
531	555	411	435	100	10	258	581	-1.0 / +1.2	~	M12A-A02-5315
502	522	312	332	60	10	~	485	-1.0 / +1.3	17.0	M12A-A03-5021
425	445	316	336	60	10	234	483	-1.0 / +1.6	15.0	M12A-A04-4251
425	441	316	332	60	8	234	483	-1.0 / +1.6	15.0	M12A-A04-4252
425	445	316	336	80	10	254	483	-1.0 / +1.6	~	M12A-A04-4253
425	445	316	336	100	10	274	483	-1.0 / +1.6	~	M12A-A04-4254
425	445	316	336	140	10	314	483	-1.0 / +1.6	~	M12A-A04-4255
425	445	316	336	160	10	334	483	-1.0 / +1.6	~	M12A-A04-4256

**Materials:**

1. M12A-A: 316L Stainless Steel
2. M12A-C: 304L Stainless Steel

**Other materials also available:**

1. L – Natural Rubber
2. E – EPDM
3. N – Nitrile
4. V – FKM

Dimensions are provided in good faith but may be subject to change, if dimensions are critical, please call the office to confirm all sizes before placing an order.

## M12A-A05 – Rectangular Manway – Outward Opening

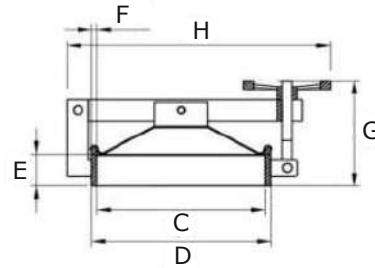

Section Detail

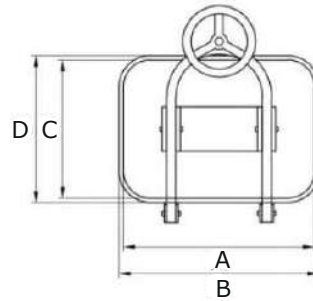

Plan Detail

A (mm)	B (mm)	C (mm)	D (mm)	E (mm)	F (mm)	G (mm)	H (mm)	Working Pressure Range (bar)	Weight (kg)	Part No
425	445	316	336	60	10	202	474	-1.0 / +0.70	14.0	M12A-A05-4251
425	441	316	332	60	8	202	474	-1.0 / +0.70	~	M12A-A05-4252
425	445	316	336	80	10	212	474	-1.0 / +0.70	~	M12A-A05-4253
425	445	316	336	100	10	222	474	-1.0 / +0.70	~	M12A-A05-4254
425	445	316	336	140	10	262	474	-1.0 / +0.70	~	M12A-A05-4255
425	445	316	336	160	10	282	474	-1.0 / +0.70	~	M12A-A05-4256

**Materials:**

1. M12A-A: 316L Stainless Steel
2. M12A-C: 304L Stainless Steel

**Other materials also available:**

1. L – Natural Rubber
2. E – EPDM
3. N – Nitrile
4. V – FKM

Lid thickness: 2 mm

Dimensions are provided in good faith but may be subject to change, if dimensions are critical, please call the office to confirm all sizes before placing an order.

[DS Rectangular Manways v1.4.doc](#)

Page No: 4

## M12A-A06 – Rectangular Manway – Outward Opening

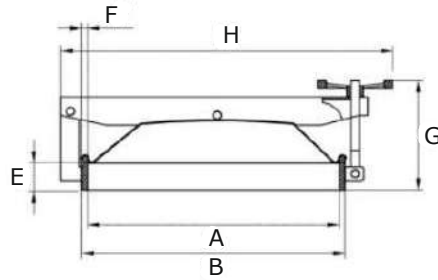

Section Detail

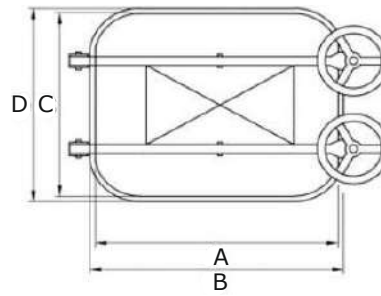

Plan Detail

A (mm)	B (mm)	C (mm)	D (mm)	E (mm)	F (mm)	G (mm)	H (mm)	Working Pressure Range (bar)	Weight (kg)	Part No
531	547	411	427	60	8	233	702	-1.0 / +1.1	22.0	<a href="#">M12A-A06-4111</a>
531	551	411	431	60	10	233	702	-1.0 / +1.1	24.0	<a href="#">M12A-A06-4112</a>
531	555	411	435	60	12	233	702	-1.0 / +1.1	26.0	<a href="#">M12A-A06-4113</a>
531	551	411	431	80	10	253	702	-1.0 / +1.1	~	<a href="#">M12A-A06-4114</a>
531	551	411	431	100	10	273	702	-1.0 / +1.1	~	<a href="#">M12A-A06-4115</a>

**Materials:**

1. M12A-A: 316L Stainless Steel
2. M12A-C: 304L Stainless Steel

**Other materials also available:**

1. L – Natural Rubber
2. E – EPDM
3. N – Nitrile
4. V – FKM

Lid thickness: 2.5 mm

Dimensions are provided in good faith but may be subject to change, if dimensions are critical, please call the office to confirm all sizes before placing an order.

## M12A-A07 – Rectangular Manway – Outward Opening

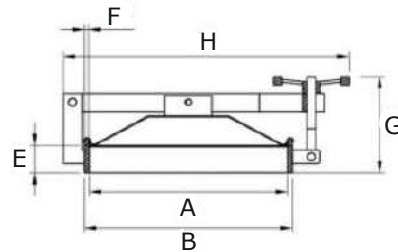

Section Detail

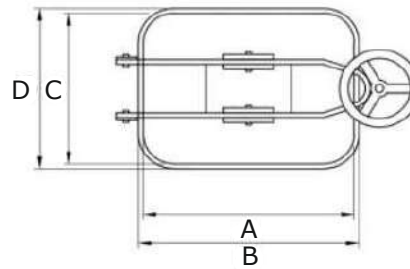

Plan Detail

A (mm)	B (mm)	C (mm)	D (mm)	E (mm)	F (mm)	G (mm)	H (mm)	Working Pressure Range (bar)	Weight (kg)	Part No
425	445	316	336	60	10	212	584	-1.0 / +0.6	15.0	<a href="#">M12A-A07-3161</a>
425	441	316	332	60	8	212	584	-1.0 / +0.6	~	<a href="#">M12A-A07-3162</a>
425	445	316	336	80	10	232	584	-1.0 / +0.6	~	<a href="#">M12A-A07-3163</a>
425	445	316	336	100	10	252	584	-1.0 / +0.6	~	<a href="#">M12A-A07-3164</a>
425	445	316	336	120	10	292	584	-1.0 / +0.6	~	<a href="#">M12A-A07-3165</a>
425	445	316	336	160	10	312	584	-1.0 / +0.6	~	<a href="#">M12A-A07-3166</a>

**Materials:**

1. M12A-A: 316L Stainless Steel
2. M12A-C: 304L Stainless Steel

**Other materials also available:**

1. L – Natural Rubber
2. E – EPDM
3. N – Nitrile
4. V – FKM

Lid thickness 2 mm

Dimensions are provided in good faith but may be subject to change, if dimensions are critical, please call the office to confirm all sizes before placing an order.

[DS Rectangular Manways v1.4.doc](#)

Page No: 6

## M12B-A12 – Rectangular Manway – Inward Opening

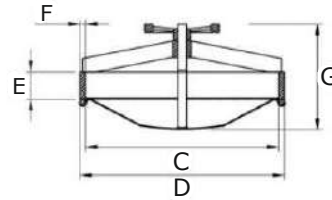

Section Detail

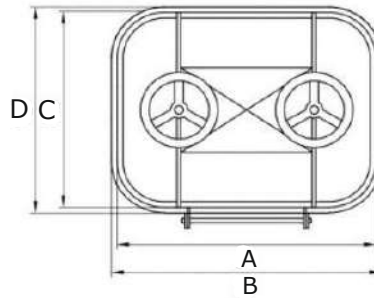

Plan Detail

A (mm)	B (mm)	C (mm)	D (mm)	E (mm)	F (mm)	G (mm)	H (mm)	Working Pressure Range (bar)	Weight (kg)	Part No
531	547	411	427	60	8	221	~	+2.20	17.0	M12B-A12-5311
531	551	411	431	60	10	221	~	+2.20	18.0	M12B-A12-5312
531	555	411	435	60	12	221	~	+2.20	20.0	M12B-A12-5313

**Materials:**

1. M12B-A: 316L Stainless Steel
2. M12B-C: 304L Stainless Steel

**Other materials also available:**

1. L – Natural Rubber
2. E – EPDM
3. N – Nitrile
4. V – FKM

Lid thickness 2.5 mm

Dimensions are provided in good faith but may be subject to change, if dimensions are critical, please call the office to confirm all sizes before placing an order.

[DS Rectangular Manways v1.4.doc](#)

Page No: 7

## M12B-A13/14 – Rectangular Manway – Inward Opening

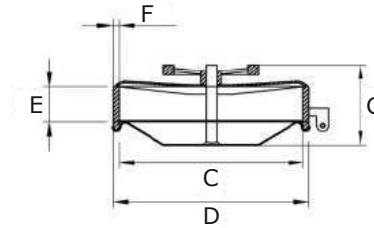

Section Detail

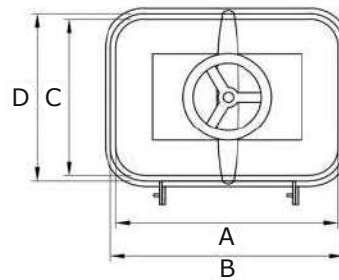

Plan Detail

A (mm)	B (mm)	C (mm)	D (mm)	E (mm)	F (mm)	G (mm)	H (mm)	Working Pressure Range (bar)	Weight (kg)	Part No
502	522	312	332	60	10	162	~	2.0	13.0	M12B-A13-5021
425	445	316	336	60	10	141	~	2.0	11.0	M12B-A14-4251

**Materials:**

1. M12B-A: 316L Stainless Steel
2. M12B-C: 304L Stainless Steel

**Other materials also available:**

1. L – Natural Rubber
2. E – EPDM
3. N – Nitrile
4. V – FKM

Dimensions are provided in good faith but may be subject to change, if dimensions are critical, please call the office to confirm all sizes before placing an order.

[DS Rectangular Manways v1.4.doc](#)

Page No: 8

## M12A-A27 – Rectangular Manway – Outward Opening

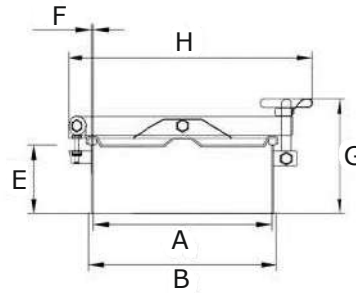

Section Detail

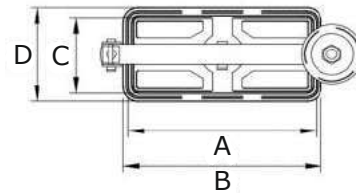

Plan Detail

A (mm)	B (mm)	C (mm)	D (mm)	E (mm)	F (mm)	G (mm)	H (mm)	Working Pressure Range (bar)	Weight (kg)	Part No
304	310	124	130	100	3	194	415	0.02	4.0	M12A-A27-1241

**Materials:**

1. M12A-A: 316L Stainless Steel
2. M12A-C: 304L Stainless Steel

**Other materials also available:**

1. L – Natural Rubber
2. E – EPDM
3. N – Nitrile
4. V – FKM

Lid thickness 2.5 mm

Dimensions are provided in good faith but may be subject to change, if dimensions are critical, please call the office to confirm all sizes before placing an order.

[DS Rectangular Manways v1.4.doc](#)

Page No: 9

## M12A-A38 – Rectangular Manway – Outward Opening

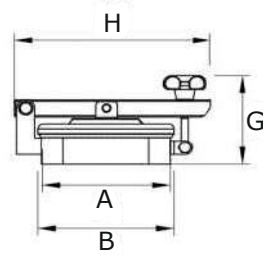

Elevation Detail

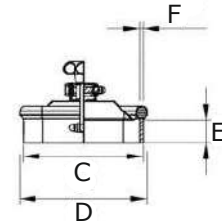

Section Detail

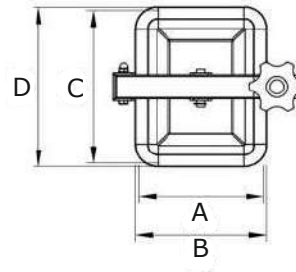

Plan Detail

A (mm)	B (mm)	C (mm)	D (mm)	E (mm)	F (mm)	G (mm)	H (mm)	Working Pressure Range (bar)	Weight (kg)	Part No
175	187	225	237	50	6	130	-	0.7	4.0	M12A-A38-2251
175	187	225	237	30	6	110	-	0.7	3.8	M12A-A38-2252
175	187	225	237	30	6	180	-	0.7	4.5	M12A-A38-2253
245	257	310	322	50	6	145	-	0.5	6.0	M12A-A38-3101
245	257	310	322	30	6	125	-	0.5	5.5	M12A-A38-3102
245	257	310	322	100	6	195	-	0.5	6.5	M12A-A38-3103

**Materials:**

1. M12A-A: 316L Stainless Steel
2. M12A-C: 304L Stainless Steel

**Other materials also available:**

1. L – Natural Rubber
2. E – EPDM
3. N – Nitrile
4. V – FKM

Lid thickness 1 mm

Dimensions are provided in good faith but may be subject to change, if dimensions are critical, please call the office to confirm all sizes before placing an order.

## M12A-A38L – Rectangular Manway – Outward Opening

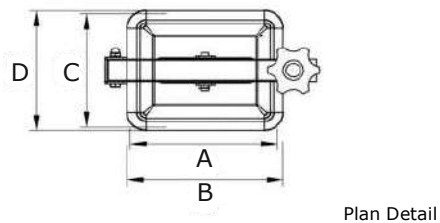
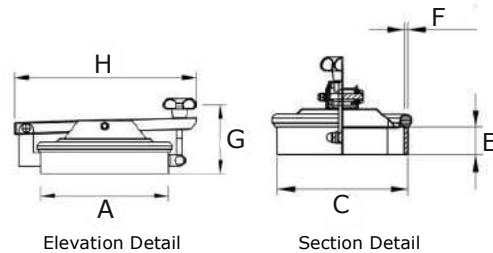

A (mm)	B (mm)	C (mm)	D (mm)	E (mm)	F (mm)	G (mm)	H (mm)	Working Pressure Range (bar)	Weight (kg)	Part No
225	237	175	187	50	6	130	-	0.7	4.0	<a href="#">M12A-A38L-1751</a>
225	237	175	187	30	6	110		0.7	3.8	<a href="#">M12A-A38L-1752</a>
225	237	175	187	100	6	180		0.7	4.5	<a href="#">M12A-A38L-1753</a>
310	322	245	257	50	6	145	-	0.7	6.0	<a href="#">M12A-A38L-2451</a>
310	322	245	257	30	6	125		0.7	5.5	<a href="#">M12A-A38L-2452</a>
310	322	245	257	100	6	195		0.7	6.5	<a href="#">M12A-A38L-2453</a>

**Materials:**

1. M12A-A: 316L Stainless Steel
2. M12A-C: 304L Stainless Steel

**Other materials also available:**

1. L – Natural Rubber
2. E – EPDM
3. N – Nitrile
4. V – FKM

Lid thickness 1 mm

Dimensions are provided in good faith but may be subject to change, if dimensions are critical, please call the office to confirm all sizes before placing an order.

[DS Rectangular Manways v1.4.doc](#)

Page No: 11