

Clamp Range

The clamp range of unions has become universally the accepted fitting of choice for much of the pharmaceutical, biotech, cosmetic and food industries. This simple design and use fitting, generally requires no tools for use, covers a wide range of pipe and tube sizes, finishes and materials and complies with all the relevant US and European standards including ASME BPE-2002, 3A, BS 4825 Part 3, DIN 32676 and ISO 2852.

The standard heavy-duty clamp has been the market leading product for over 15 years and is available in sizes from 4mm to 12" encompassing both imperial, metric and schedule pipe sizes. High pressure clamps are available from 1" to 12" while the light duty clamps are available from ½" to 6" in the single hinge pin design.

A full range of standard and special clamps is now offered including the 3 Segment clamp and the retro Clamp range of 13 MHHM with single and double, hinge mechanism.



Standards:

ASME BPE-2002
BS 4825 Part 3 / ISO 2037
DIN 32676
DIN 11864-3
3A Standard
ISO 2852 and SMS 3017
SMS 3008
ISO 1127 Schedule Pipe Size
BS 6362 Schedule Pipe Size
ASTM A312 Schedule Pipe

Dimensions are provided in good faith but may be subject to change; if dimensions are critical please call the office to confirm all sizes before placing an order.

[DS: Clamp Range V1.6](#)

Page No: 1

3017 - Single Pin Clamp Series – 304 SS

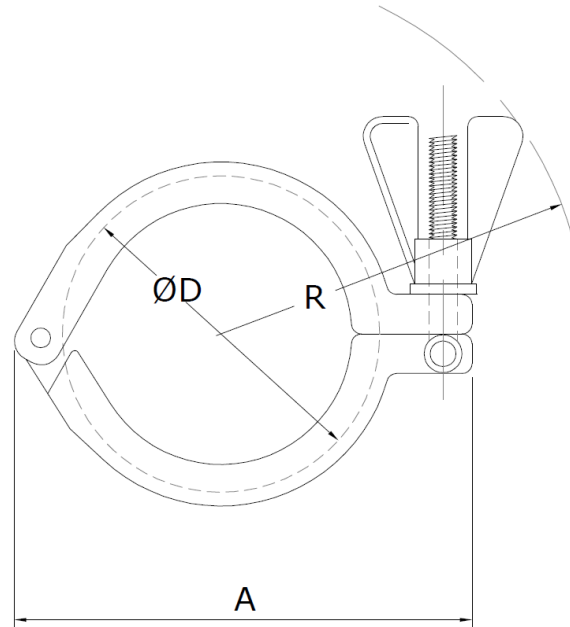

Size	D Ø Flange	R Radius	A Length	Max Working Pressure (Bar) 150°C	Weight (kg)	Part No
1/2" - 3/4"	25.4	63.0	60.0	25	0.13	3017-C013-019
DN10-15-20	34.0	73.0	69.0	25	0.17	3017-C010-020
1" - 1.1/2"	50.5	78.0	85.0	25	0.21	3017-C026-038
2"	64.0	82.0	99.0	25	0.25	3017-C051
2.1/2"	77.5	89.0	112.0	25	0.35	3017-C064
3"	91.0	96.0	126.0	20	0.42	3017-C076
3.1/2"	106.0	103.0	140.0	20	0.44	3017-C089
4"	119.0	110.0	154.0	17	0.51	3017-C102
4.1/2"	130.0	115.0	165.0	15	0.60	3017-C114
6"	167.0	134.0	216.0	N/A	0.88	3017-C154

Dimensions are provided in good faith but may be subject to change; if dimensions are critical please call the office to confirm all sizes before placing an order.

DS: [Clamp Range V1.6](#)

Page No: 2

3018 - Heavy Duty Clamp - 316 SS - Single Nut

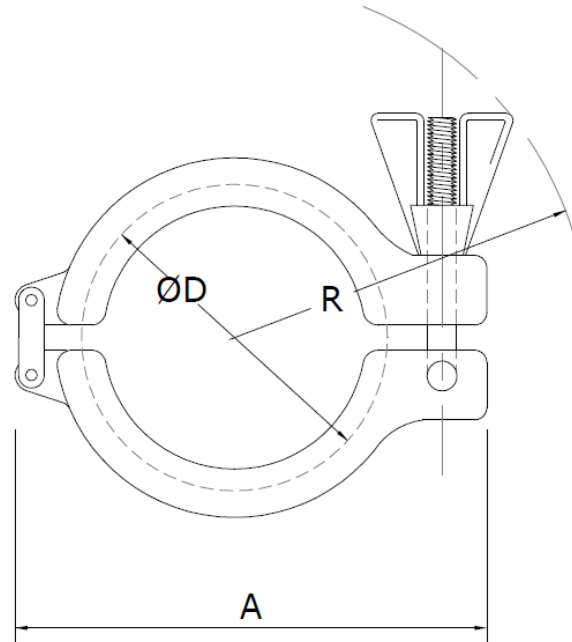

Size	D Ø Flange	R Radius	A Length	Max Working Pressure (Bar) 150°C	Weight (kg)	Part No
½" - ¾"	25.4	63.0	75.0	50	0.15	3018-B013-019
DN 10-15-20	34.0	67.0	85.0	50	0.17	3018-B010-020
1" - 1.½"	50.5	77.0	102.0	50	0.25	3018-B026-038
2"	64.0	93.0	123.0	50	0.33	3018-B051
2.½"	77.5	100.0	140.0	40	0.38	3018-B064
3"	91.0	105.0	150.0	40	0.44	3018-B076
3.½"	106.0	110.0	165.0	40	0.44	3018-B089
4"	119.0	119.0	185.0	35	0.57	3018-B102
4.½"	130.0	120.0	191.0	30	0.60	3018-B114
5"	144.0	131.0	215.0	30	0.75	3018-B129
5.½"	155.0	155.0	252.0	30	1.39	3018-B141
6"	167.0	156.0	262.0	30	1.45	3018-B154
6.⅝"	183.0	178.0	280.0	25	1.61	3018-B168
8"	217.0	195.0	325.0	20	2.11	3018-B204
8.⅝"	233.0	203.0	333.0	20	2.25	3018-B219
10" *	268.0	205.0	382.0	16	2.78	3018-B254
10.⅝" *	286.0	213.0	405.0	16	2.97	3018-B273
12" *	319.0	242.0	458.0	10	3.37	3018-B304
12.¾" *	338.0	243.0	463.0	10	3.69	3018-B324
*items have double Wing Bolts						

Dimensions are provided in good faith but may be subject to change; if dimensions are critical please call the office to confirm all sizes before placing an order.

3019 - Clamp - 304SS – SSH Type - High Pressure

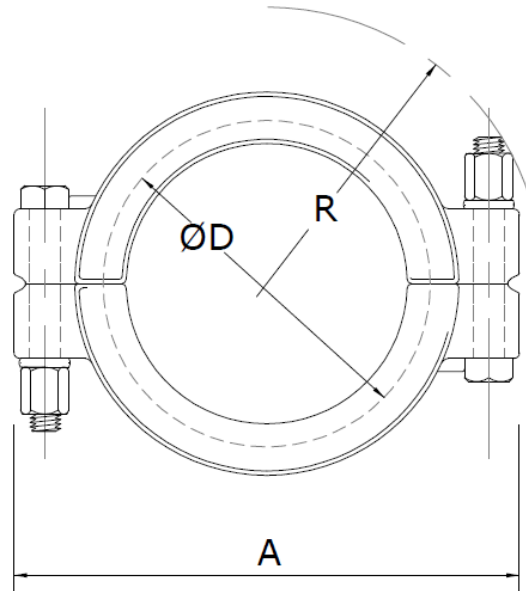

Size	D Ø Flange	R Radius	A Length	Max Working Pressure (Bar) 150°C	Weight (kg)	Part No
½" - ¾"	25.4	37.0	65.0	75	0.16	3019-C013-019
DN 10/15/20	34.0	42.0	74.0	75	0.22	3019-C010-020
1" - 1.½"	50.5	64.0	103.0	75	0.66	3019-C026-038
2"	64.0	73.0	113.0	75	0.82	3019-C051
2.½"	77.5	80.0	128.0	75	0.94	3019-C064
3"	91.0	86.0	137.0	60	1.02	3019-C076
3.½"	106.0	94.0	150.0	60	1.07	3019-C089
4"	119.0	102.0	165.0	53	1.27	3019-C102
4.½"	130.0	105.0	174.0	45	1.33	3019-C114
5.½"	155.0	125.0	226.0	45	1.90	3019-C141
6"	167.0	132.0	240.0	45	1.93	3019-C154
6.⅝"	183.0	142.0	260.0	38	2.11	3019-C168
8.⅝"	233.0	168.0	318.0	30	2.52	3019-C219
<ul style="list-style-type: none"> Material – 304SS with Brass Nuts (SS available as an option) 						

Dimensions are provided in good faith but may be subject to change; if dimensions are critical please call the office to confirm all sizes before placing an order.

3019 - Clamp - 304SS – 13MHP - High Pressure

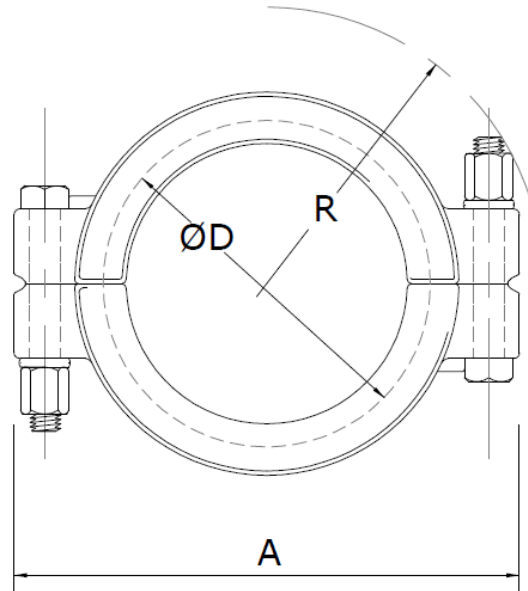

Size	D Ø Flange	R Radius	A Length	Pressure Rating(Bar) 90°C	Pressure Rating (Psi) 90°C	Part No
1" - 1.½"	50.5	64.0	103.0	50	725	3019-C026-MHP
2"	64.0	73.0	113.0	50	725	3019-C051-MHP
2.½"	77.5	80.0	128.0	50	725	3019-C064-MHP
3"	91.0	86.0	137.0	40	580	3019-C076-MHP
3.½"	106.0	94.0	150.0	30	435	3019-C089-MHP
4"	119.0	102.0	165.0	25	363	3019-C102-MHP
4.½"	130.0	105.0	174.0	25	363	3019-C114-MHP
5.½"	155.0	125.0	226.0	25	363	3019-C141-MHP
6"	167.0	132.0	240.0	20	290	3019-C154-MHP
6.¾"	183.0	142.0	260.0	20	290	3019-C168-MHP
8.¾"	233.0	168.0	318.0	15	218	3019-C219-MHP
<ul style="list-style-type: none"> Material – 304SS with Brass Nuts (SS available as an option) 						

Dimensions are provided in good faith but may be subject to change; if dimensions are critical please call the office to confirm all sizes before placing an order.

3025 - Clamp - 304SS - Heavy Duty - F2 Nut

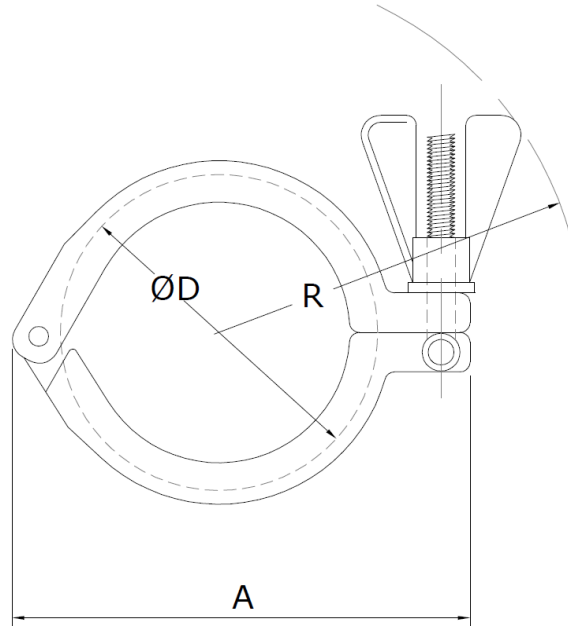

Size	D Ø Flange	R Radius	A Length	Max Working Pressure (Bar) 20°C	Weight (kg)	Part No
6"	167	145	217	10	0.80	3025-C154-F2N
6.5/8"	183	155	230	N/A	0.95	3025-C168-F2N
8"	217	165	270	5	1.10	3025-C204-F2N
8.5/8"	233	280	280	N/A	1.20	3025-C219-F2N
10"	268	330	330	N/A	1.70	3025-C254-F2N
10.5/8"	286	350	350	N/A	1.70	3025-C273-F2N
12"	319	390	390	N/A	3.00	3025-C304-F2N

Dimensions are provided in good faith but may be subject to change; if dimensions are critical please call the office to confirm all sizes before placing an order.

DS: [Clamp Range V1.6](#)

Page No: 6

012R – Flat Grip Pressure Vessel Clamps

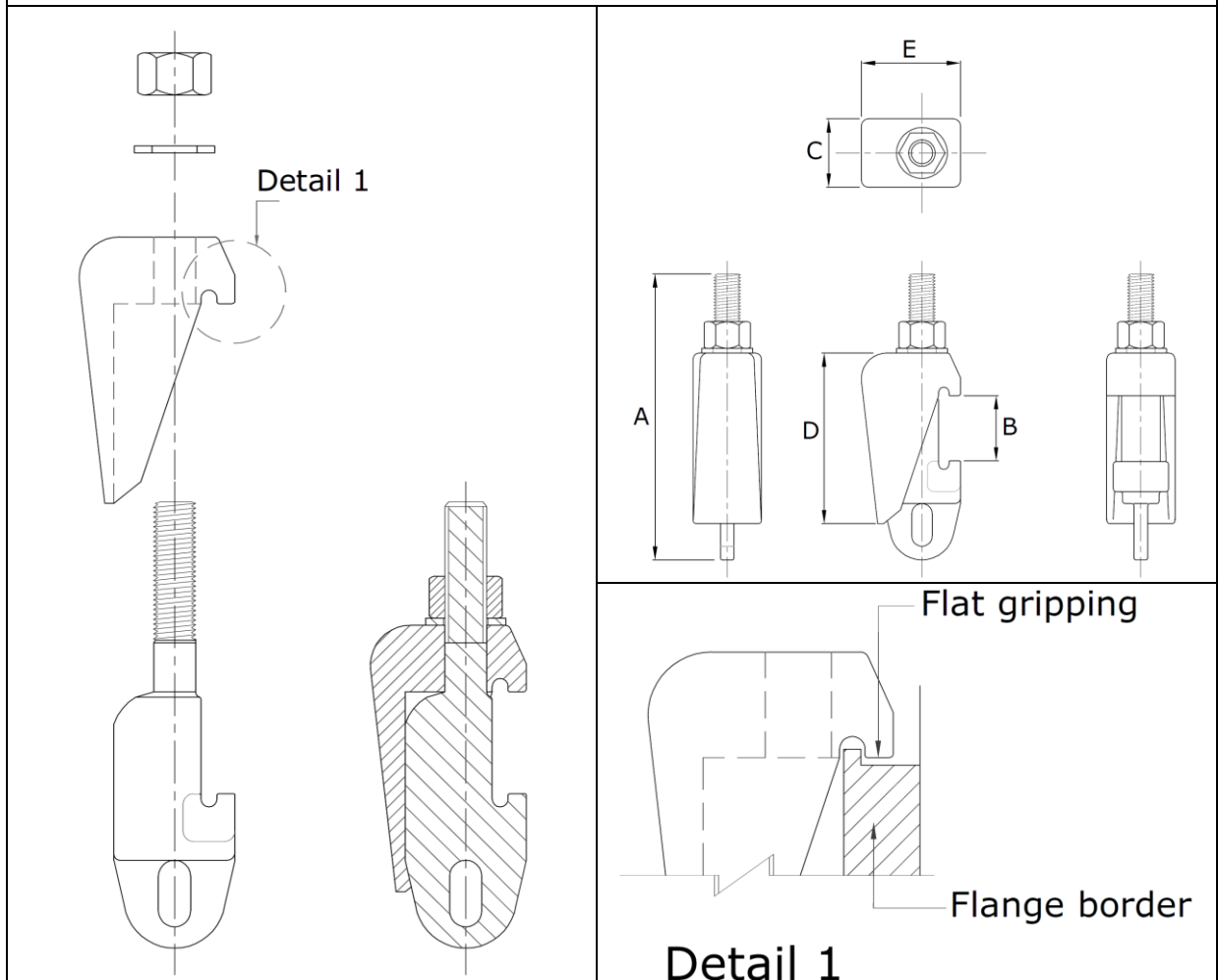

Size	A	B	C	D	E	Weight kgs	Part No
M10 - K	83	13 - 24	25	43	27	0,16	012R-ZM10-024HO
M10 - L	94	22 - 33	25	43	27	0,18	012R-ZM10-033HO
M10 - LS	122	70 - 83	-	-	-	-	012R-ZM10-083HO
M12 - L	133	40 - 56	34	70	38	0,50	012R-ZM12-056HO
M16 - K	165	40 - 60	40	100	58	1,13	012R-ZM16-060HO
M16 - L	192	55 - 85	40	100	58	1,21	012R-ZM16-085HO
M16 - L2	213	80 - 110	40	100	58	1,28	012R-ZM16-110HO
M16 - LS	234	95 - 125	40	100	58	1,40	012R-ZM16-125HO
M20 - K	200	50 - 75	45	115	73	1,95	012R-ZM20-075HO
M20 - L	212	65 - 90	45	115	73	2,00	012R-ZM20-090HO
M20 - L2	252	90 - 130	45	115	73	2,20	012R-ZM20-130HO
M24 - K	230	65 - 95	52	130	78	2,65	012R-ZM24-095HO
M24 - L	265	90 - 130	52	130	78	3,00	012R-ZM24-130HO
M24 - L2	295	120 - 160	52	130	78	3,20	012R-ZM24-160HO
M24 - LS	340	155 - 200	52	130	78	3,40	012R-ZM24-200HO

Dimensions are provided in good faith but may be subject to change; if dimensions are critical please call the office to confirm all sizes before placing an order.

M24 – LP	404	180 - 260	52	130	78	4,40	012R-ZM24-260HO
M24 – LX	470	290 - 330	-	-	-	-	012R-ZM24-330HO
Size	A	B	C	D	E	Weight kgs	Part No
M27 – K	290	90 - 110	63	155	85	4,80	012R-ZM27-110HO
M27 – L	327	115 - 145	63	155	85	5,00	012R-ZM27-145HO
M27 – L2	375	150 - 195	63	155	85	5,15	012R-ZM27-195HO
M27 – L3	435	205 - 255	63	155	85	6,15	012R-ZM27-255HO
M27 – BV	480	250 - 300	63	155	85	7,20	012R-ZM27-300HO
M27 – LS	565	340 - 385	63	155	85	7,70	012R-ZM27-385HO
M27 – LX	680	440 - 480	-	-	-	-	012R-ZM27-480HO
M33 – K	380	100 - 150	70	200	102	9,20	012R-ZM33-150HO
M33 – L	430	150 - 200	70	200	102	10,10	012R-ZM33-200HO
M33 – Spc.	440	180 - 220	70	200	102	10,20	012R-ZM33-220HO
M33 – L2	480	200 - 250	70	200	102	10,80	012R-ZM33-250HO
M33 – L3	530	250 - 300	70	200	102	11,40	012R-ZM33-300HO
M33 – L4	550	280 - 320	70	200	102	12,00	012R-ZM33-320HO
M33 – L5	645	365 - 415	70	200	102	12,80	012R-ZM33-415HO
M33 – LX	655	380 - 430	-	-	-	-	012R-ZM33-430HO
M33 – LY	810	510 - 560	-	-	-	-	012R-ZM33-560HO
M56 – L	523	200 - 245	-	-	-	-	012R-ZM56-130HO
M56 – L2	640	260 - 350	-	-	-	-	012R-ZM56-130HO
M56 – L3	705	380 - 420	-	-	-	-	012R-ZM56-130HO
	<p>Material:</p> <ul style="list-style-type: none"> Carbon Steel Zinc or Nickel Plated 316 Stainless Steel <p>Standard Assembling:</p> <ul style="list-style-type: none"> Hex Through Nut: HO Hex Cap Nut: HC Swing Nut, Eye Nut and others are available upon request <p>Items in bold are made upon request</p>						

Dimensions are provided in good faith but may be subject to change; if dimensions are critical please call the office to confirm all sizes before placing an order.

012Q – Round Grip Pressure Vessel Clamps

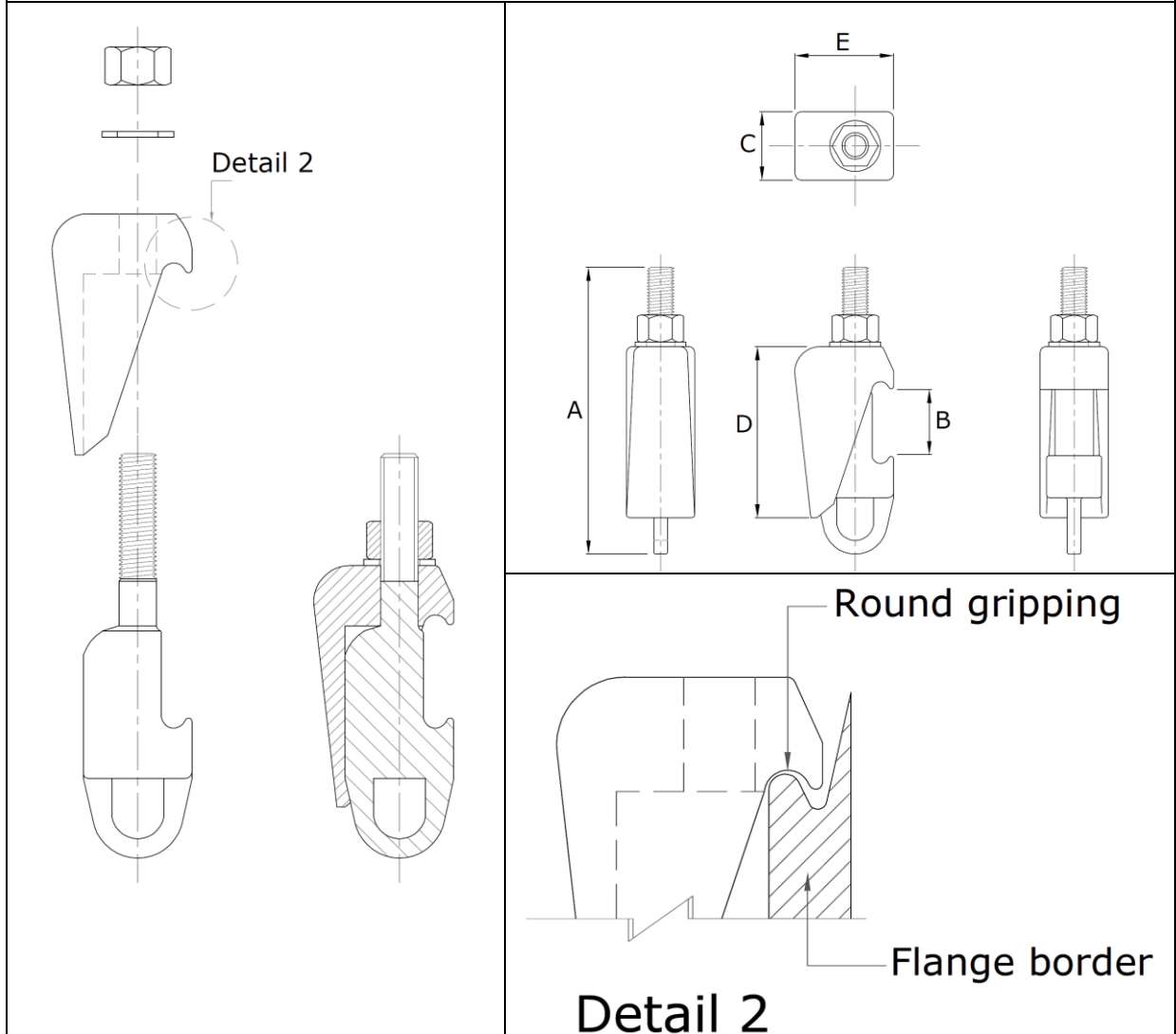

Size	A	B	C	D	E	Weight kgs	Part No
M16 (5/8")	180	50 - 75	45	86	62	1,40	012Q-ZM16-075HO
M16 (5/8")	225	95 - 120	45	86	62	1,50	012Q-ZM16-120HO
M20 (3/4")	195	60 - 85	50	95	69	1,80	012Q-ZM20-085HO
M20 (3/4")	235	95 - 120	50	95	69	2,50	012Q-ZM20-120HO
M24 (1")	217	75 - 100	54	112	74	2,61	012Q-ZM24-100HO
M24 (1")	233	90 - 115	54	112	74	2,71	012Q-ZM24-115HO
M24 (1")	252	110 - 135	54	112	74	3,00	012Q-ZM24-135HO
M24 (1")	303	150 - 185	54	112	74	3,20	012Q-ZM24-185HO
M27 (1.1/16")	288	85 - 120	60	155	90	5,00	012Q-ZM27-120HO

Dimensions are provided in good faith but may be subject to change; if dimensions are critical please call the office to confirm all sizes before placing an order.

DS: [Clamp Range V1.6](#)

Page No: 9

M27 (1.1/16")	323	120 - 155	60	155	90	5,30	012Q-ZM27-155HO
M27 (1.1/16")	357	155 - 190	60	155	90	5,50	012Q-ZM27-190HO
M30 (1.1/8")	288	85 - 120	60	155	90	5,40	012Q-ZM30-120HO
M30 (1.1/8")	323	120 - 155	60	155	90	5,70	012Q-ZM30-155HO
M30 (1.1/8")	357	155 - 190	60	155	90	5,90	012Q-ZM30-190HO
Size	A	B	C	D	E	Weight Kgs	Part No
M33 (1.1/4)	375	120 - 160	70	200	100	8,80	012Q-ZM33-160HO
M33 (1.1/4)	440	180 - 220	70	200	100	10,20	012Q-ZM33-220HO
	<p>Material:</p> <ul style="list-style-type: none"> • Carbon Steel Zinc or Nickel Plated • 316 Stainless Steel <p>Standard Assembling:</p> <ul style="list-style-type: none"> • Hex Through Nut: HO • Hex Cap Nut: HC • Swing Nut, Eye Nut and others are available upon request <p>Items in bold are made upon request</p>						

Dimensions are provided in good faith but may be subject to change; if dimensions are critical please call the office to confirm all sizes before placing an order.